

HX10E 1150X540 INOX

STAINLESS STEEL ELECTRIC SCISSOR LIFT - IP65



STAINLESS STEEL

The HX10E stainless steel scissor lift makes possible an easy and light lifting to a height of 800 mm thanks to the reliable electric motor and to the powerful GEL battery keeping the goods at the suitable height to collect/deposit the loads, reducing the operator's effort. Entirely built in stainless steel AISI 304 (including the pump and the hydraulic components) suitable to work in the aggressive and corrosive environments where the cleaning and the hygiene are the most required values and where there is serious problem of corrosion related to the use of corrosive acids and saline solutions.



EQUIPPED FOR DEMANDING APPLICATIONS

IP65 protection, AISI 304 stainless steel electro polished, sealed waterproof bearings, polyamide bushings make HX10E INOX match the food industry regulations. It is the ideal and clean solution for the handling in the agrifood, chemical and pharmaceutical industries. It is corrosion-proof, maneuverable and ergonomic and it is built to withstand regular high-pressure cleaning and disinfection satisfying the strictest hygienic regulations.



TILLER

The handle offers an ergonomic tiller and an electric switch for lifting and lowering operations. The tiller design ensures operator comfort on pushing operations.

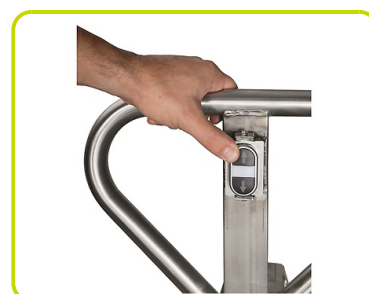

REAR STABILIZERS

The control linkage makes possible the entry on the closed side of the pallet by a slight lifting, which facilitates the successive handling phases. Furthermore, machine stability is achieved by using load rollers in a more advanced position. Work is made stable and safe with the rear stabilizers, also when the working height exceeds the 400 mm and in the case of heavy loads.

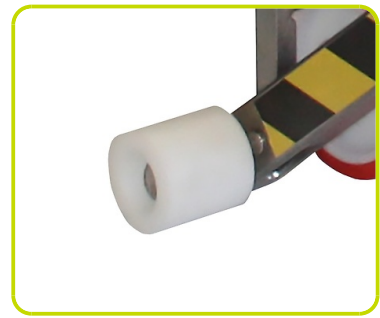

SAFETY AND EFFICIENCY

The emergency pushbutton with function of battery cut-off switch (isolator) and the off-load valve allowing a smoother lowering of the load are some of the devices that make the work safer and more efficient.



STANDARD EQUIPMENT

GEL 12V/75Ah battery: big size for long endurance also on low temperature environment, deep cycle gel is safe (no acid – vapor spilling out) and do not need maintenance.

ON-BOARD battery charger with extendable power charger cable.

Battery status indicator visible from the maneuvering station.



EASY MAINTENANCE

Simple construction with a design that allows a really easy maintenance: the access to lifting motor, battery and charger can be done just removing few bolts and without lifting the unit.



ADJUSTABLE FORK LOWERING SPEED

The machine is equipped with an adjustable valve that regulates the oil flow during the lowering operation. This means to have the possibility to regulate the lowering fork speed depending on the various application. Such adjustment can be easily done through the knob positioned inside the battery compartment.

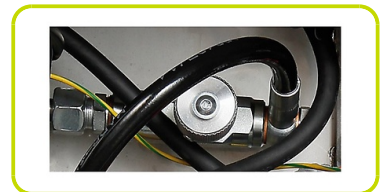

CERTIFICATIONS

The design of HX10 INOX Scissor Lift makes the machine compliant to:
UNI EN 1672-1: 2014 (product for alimentary business – basic concept)
UNI EN 1672-2: 2009 (product for alimentary business – hygienic concept)



OPTIONS

- Stainless steel AISI 316
- Tailor-made chassis to handle special loads
- Custom forks length and width



Description

1.3 Drive			Manual
1.4 Operator type			Pedestrian
1.5 Load capacity	Q	Kg	1000
1.6 Load centre distance	c	mm	600
1.8 Load axle to end forks	x	mm	155
1.9 Wheel base	y	mm	1230

Weights

2.1 Service weight		Kg	150
2.2 Axle load, laden rear		Kg	610
2.2 Axle load, laden front		Kg	542
2.3 Axle load, unladen front		Kg	42
2.3 Axle load, unladen rear		Kg	110

Tyres/Chassis

3.1 Tyres: front wheels			NYLON/POLY
3.1 Tyres: rear wheels			POLY
3.2 Tyre size: Steering wheels - Width		mm	85
3.2 Tyre size: Steering wheels - Diameter		mm	175
3.3 Tyre size: Load rollers - Diameter		mm	82
3.3 Tyre size: Load rollers - Width		mm	90
3.5 Tyre size: rear wheels - Q.ty (X=driven)		nr	2
3.5 Tyre size: front wheels - Q.ty (X=driven)		nr	2
3.6 Tread, front	b10	mm	550
3.7 Tread, rear	b11	mm	550

Dimensions

4.4 Lift height	h3	mm	715
4.9 Height of tiller in drive position min	h14	mm	1190
4.15 Height, lowered	h13	mm	85
4.19 Overall length	l1	mm	1740
4.20 Length to face of forks	l2	mm	590
4.21 Overall width	b1	mm	550
4.22 Fork dimensions - Thickness	s	mm	85
4.22 Fork dimensions - Width	e	mm	170
4.22 Fork dimensions - Length	l	mm	1150
4.25 Distance between fork arms	b5	mm	550
4.32 Ground clearance, centre of wheelbase	m2	mm	30
4.34 Aisle width	Ast	mm	1950
4.35 Turning radius	Wa	mm	1345

Electric motors

6.2 Lift motor power	kW	0.8
Battery Type	Tipo	GEL
6.4 Battery voltage	V	12
6.4 Battery capacity, Min	Ah	75
6.4 Battery capacity, Max	Ah	75
6.5 Battery weight, Min	Kg	23.5
6.5 Battery weight, Max	Kg	23.5
8.4 Sound level at driver's ear	dB(A)	67

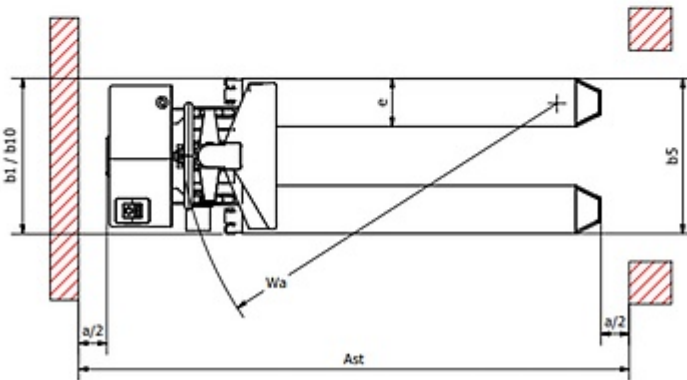
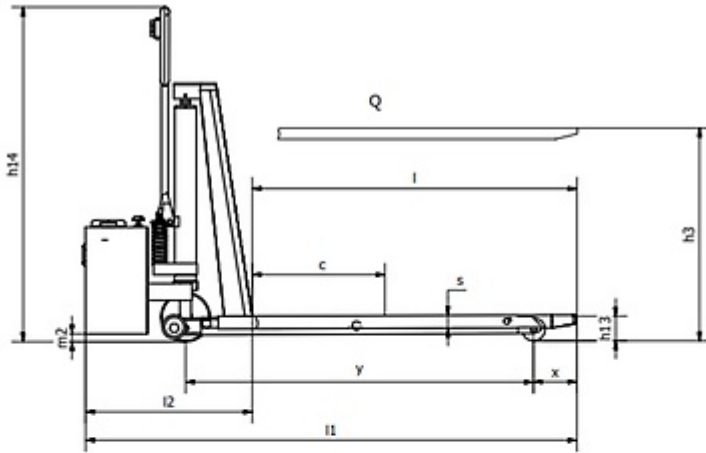

The information is aligned with the Data file at the time of download. Printed on 12/08/2020 (ID 11239)

©2019 | PR INDUSTRIAL s.r.l. | All rights reserved | Image shown may not reflect actual package. Specifications subject to change without notice

